

SW Series – Part Numbering



Features

- Excellent performance at low cost
- Screw mounting assures solid connection
- Rubber gasket assures water resistance
- Manufactured with precision

Applications

- Professional audio and video
- CCTV system
- Vision related testing equipment
- Portable wireless radio
- Measuring equipment
- Computers and peripherals
- Medical, and much more.

Part Numbering

Part Number		Size	Number of Contact	Suffix	Optional Suffix	Notes	Page
Series	Prefix				S		
SW		8 or 10	8 size : 4,5,6 10 size : 2,3,4,9,10,12	P	●	Main SW Series	66
				R / RPCB	●		
	H			P	●	SWH Series (SW with reverse contacts)	67
				R / RPCB	●		
	A	P	●	SWA Series (Adapter for SW series)	66		
	HA			●	SWhA Series (Adapter for SWH series)	67	

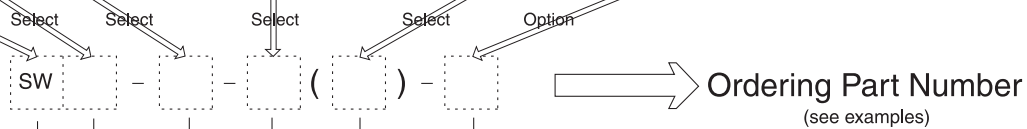

Connector Series

SW
 SWH - reverse contact
 SWA - adapter for SN series
 SWHA - adapter for SNH series

Size

8,10

No. of Contact

8 Size : 4,5,6
 10 Size : 2,3,4,9,10,12

Body Type

P : Plug
 R : Receptacle (solder termination)
 RPCB : Receptacle (PCB termination)
 blank : Adapter

Optional

S : Silver contacts

Examples

SW - 8 - 4 (P)

SW series - Size 8 - 4 contacts (Plug shell)

SW - 10 - 12 (R) - S

SW series - Size 10 - 12 contacts (Receptacle / Solder contact termination) - Silver contacts

SWA - 10 - 2



Adapter for SW series - Size 10 - 2 contacts

SWhA - 8 - 6 - 2

Adapter for SWH series - Size 8 - 6 contacts - Silver contacts

Specifications subject to change without notice. Consult Sam Woo Electronics for the latest specifications.

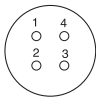
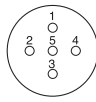
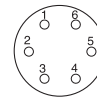
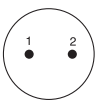
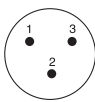
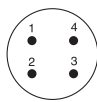
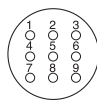
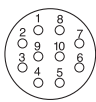
Major Performances / Contact Arrangements

Performance	Size / No of Contacts		Size 8			
	4	5	5	6	6	6
Withstanding Voltage (per min) ¹	AC 300V	AC 300V	AC 300V	AC 300V	AC 300V	AC 300V
Current	2A	2A	2A	2A	2A	2A
Insulation Resistance (Minimum) ²	1,000MΩ	1,000MΩ	1,000MΩ	1,000MΩ	1,000MΩ	1,000MΩ
Contact Resistance (Maximum) ³	10mΩ	10mΩ	10mΩ	10mΩ	10mΩ	10mΩ
Solder Pot Inside Diameter	Ø0.7	Ø0.7	Ø0.7	Ø0.7	Ø0.7	Ø0.7
Contact Arrangement						
Performance	Size / No of Contacts		Size 10			
	2	3	4	9	10	12
Withstanding Voltage (per min) ¹	AC 500V	AC 500V	AC 500V	AC 300V	AC 300V	AC 300V
Current	3A	3A	3A	2A	2A	2A
Insulation Resistance (Minimum) ²	1,000MΩ	1,000MΩ	1,000MΩ	1,000MΩ	1,000MΩ	1,000MΩ
Contact Resistance (Maximum) ³	10mΩ	10mΩ	10mΩ	10mΩ	10mΩ	10mΩ
Solder Pot Inside Diameter	Ø1.0	Ø1.0	Ø1.0	Ø0.7	Ø0.7	Ø0.7
Contact Arrangement						

- ¹ Withstanding voltage is the tested voltage value in this table.
² Insulation resistance is measured at DC 100V.
³ Contact resistance is measured at DC 1A.
 • Values are from tested items and may not apply to all connectors.
 • Specifications subject to change without notice.
 • Consult Sam Woo Electronics for the latest specifications.

Contact Diameter
 ○ 0.55mm ● 1.0mm

Material Used / Finishing Material

	Material	Finish
Body	Brass	Sn, Ni plate
Insulator	PA	Black
Contacts	Pin	Brass
	Socket	Phosphor bronze

SW Series Mini-map

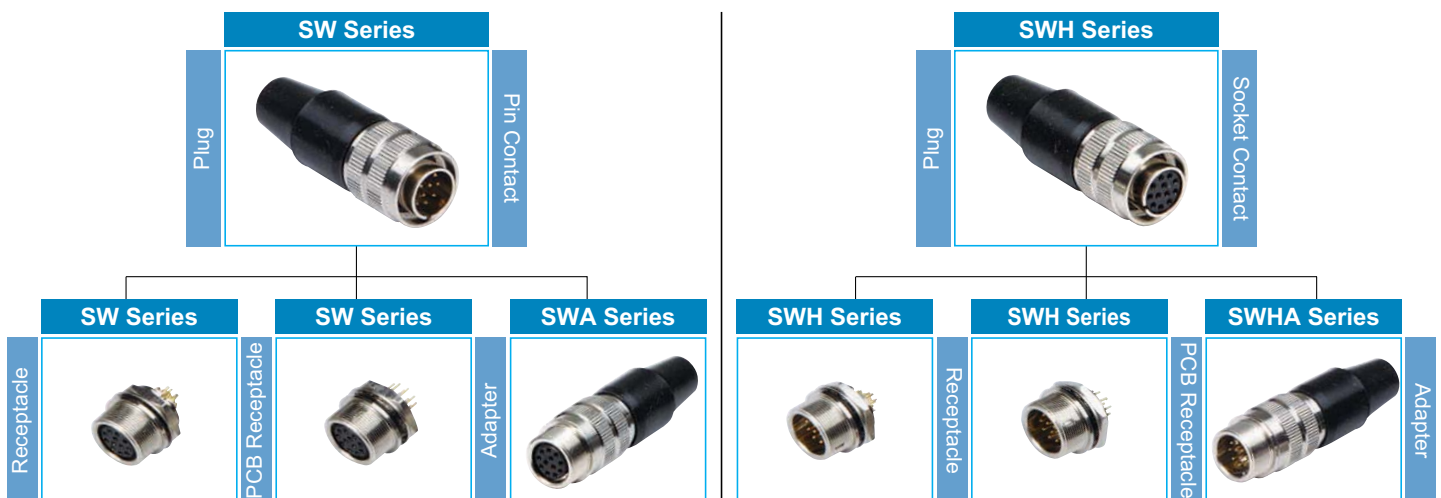

Specifications subject to change without notice. Consult Sam Woo Electronics for the latest specifications.

SW Series – SW Plug, Receptacle, Adapter



SW Plug

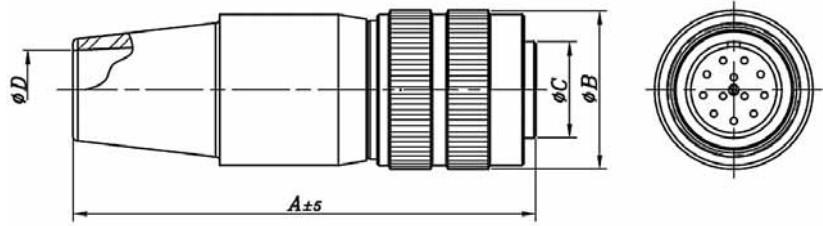

SW-10-12(P)

Part Number	A	ØB	ØC	ØD
SW-8-4 (P)	35	11	6.7	5.1
SW-8-5 (P)				
SW-8-6 (P)				

→ SW Series
→ Size
→ No. of Contacts

Part Number	A	ØB	ØC	ØD
SW-10- 2 (P)	42	14	8.5	7
SW-10- 3 (P)				
SW-10- 4 (P)				
SW-10- 9 (P)				
SW-10-10 (P)				
SW-10-12 (P)				

Silver contacts

Include '-S' at end of part number.
EX) SW-8-4 (P)-S
SW-10-12 (P)-S

SW Solder Type Receptacle



SW-10-12 (R)

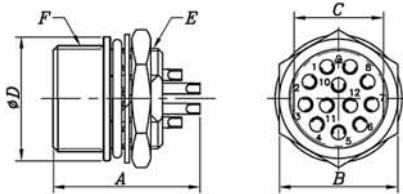

Part Number	A	B	C	ØD	E	F
SW- 8- 4 (R)	14.5	10	7.5	10	M8×0.5	M9×0.5
SW- 8- 5 (R)						
SW- 8- 6 (R)						
SW-10- 2 (R)	15	13	9.8	13.5	M11×0.75	M11.5×0.5
SW-10- 3 (R)						
SW-10- 4 (R)	16.5	13	9.8	13.5	M11×0.75	M11.5×0.5
SW-10- 9 (R)						
SW-10-10 (R)						
SW-10-12 (R)						

SW PCB Type Receptacle



SW-10-12 (RPCB)

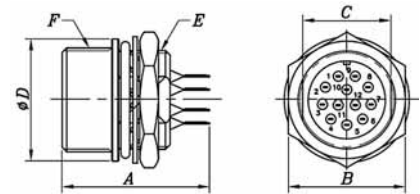

Part Number	A	B	C	ØD	E	F
SW- 8- 4 (RPCB)	15.7	10	7.5	10	M8×0.5	M9×0.5
SW- 8- 5 (RPCB)						
SW- 8- 6 (RPCB)						
SW-10- 9(RPCB)	15.7	13	9.8	13.5	M11×0.75	M11.5×0.5
SW-10-10(RPCB)						
SW-10-12(RPCB)						

Silver contacts

Include '-S' at end of part number.
EX) SW-8-4 (RPCB)-S
SW-10-12 (R)-S

SW Adapter

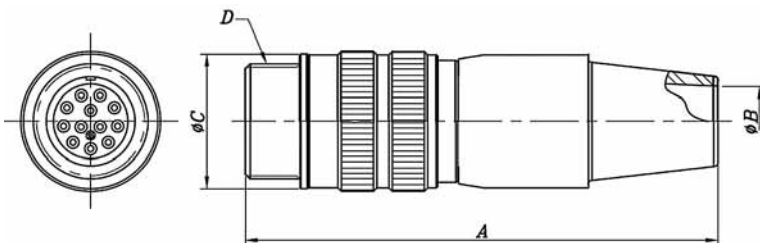

Part Number	A	ØB	ØC	D
SWA-8-4	39.3	5.1	10	M9×0.5
SWA-8-5				
SWA-8-6				

→ SWA Series
→ Size
→ No. of Contacts

Part Number	A	ØB	ØC	D
SWA-10- 2	47	7	13.5	M11.5×0.5
SWA-10- 3				
SWA-10- 4				
SWA-10- 9				
SWA-10-10				
SWA-10-12				



SWA-10-12

Silver contacts

Include '-S' at end of part number.
EX) SWA-8-4-S
SWA-10-12-S

Specifications subject to change without notice. Consult Sam Woo Electronics for the latest specifications.

SWH Plug, Receptacle, Adapter – SW Series

SWH Plug

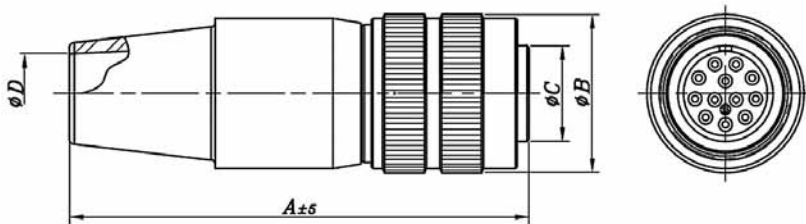

SW-10-12(P)

Part Number	A	ØB	ØC	ØD
SWH-8-4 (P)	35	11	6.7	5.1
SWH-8-5 (P)				
SWH-8-6 (P)				

Part Number	A	ØB	ØC	ØD
SWH-10- 2 (P)	42	14	8.5	7
SWH-10- 3 (P)				
SWH-10- 4 (P)				
SWH-10- 9 (P)				
SWH-10-10 (P)				
SWH-10-12 (P)				

Silver contacts

Include '-S' at end of part number.
EX) SWH-8-4 (P)-S
SWH-10-12 (P)-S

→ SWH Series
→ Size
→ No. of Contacts

SWH Solder Type Receptacle



SWH-10-12 (R)

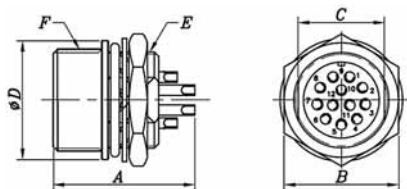

Part Number	A	B	C	ØD	E	F
SWH- 8- 4 (R)	14.2	10	7.5	10	M8×0.5	M9×0.5
SWH- 8- 5 (R)						
SWH- 8- 6 (R)						
SWH-10- 2 (R)	16.2	13	9.8	13.5	M11×0.75	M11.5×0.5
SWH-10- 3 (R)						
SWH-10- 4 (R)						
SWH-10- 9 (R)						
SWH-10-10 (R)						
SWH-10-12 (R)						

SWH PCB Type Receptacle



SWH-10-12 (RPCB)

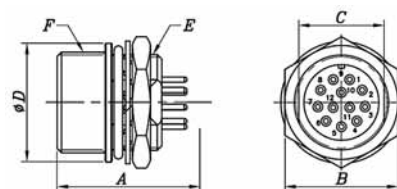

Part Number	A	B	C	ØD	E	F
SWH- 8- 4 (RPCB)	15	10	7.5	10	M8×0.5	M9×0.5
SWH- 8- 5 (RPCB)						
SWH- 8- 6 (RPCB)						
SWH-10- 9(RPCB)	15	13	9.8	13.5	M11×0.75	M11.5×0.5
SWH-10-10(RPCB)						
SWH-10-12(RPCB)						

Silver contacts

Include '-S' at end of part number.
EX) SWH-8-4 (RPCB)-S
SWH-10-12 (R)-S



SWHA-10-12

SWHA Adapter

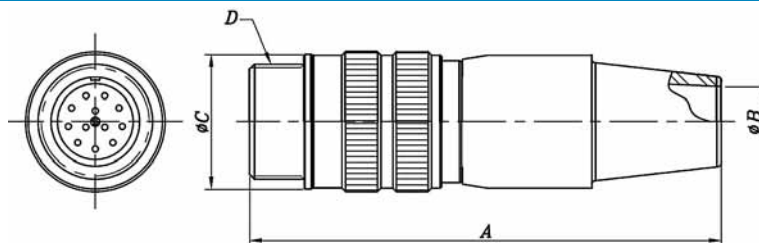

Part Number	A	ØB	ØC	D
SWHA-8-4	39.3	5.1	10	M9×0.5
SWHA-8-5				
SWHA-8-6				

Part Number	A	ØB	ØC	D
SWHA-10- 2	47	7	13.5	M11.5×0.5
SWHA-10- 3				
SWHA-10- 4				
SWHA-10- 9				
SWHA-10-10				
SWHA-10-12				

Silver contacts
Include '-S' at end of part number.
EX) SWHA-8-4-S
SWHA-10-12-S

→ SWHA Series
→ Size
→ No. of Contacts

Specifications subject to change without notice. Consult Sam Woo Electronics for the latest specifications.

SW Series – Cable Assembly Instruction

General Instruction / Information

- Diagram 1 show a sample wiring for SW series.
- Soldering must be done as quickly and carefully as possible to prevent damage to insulator.
- Receptacles do not require additional instructions.

Wiring Sequence

- ① Select cable according to outer diameter and cross section, lower than 0.129mm^2 (AWG#26).
- ② Insert RUBBER BUSHING to cable.
- ③ Insert PLUG HOUSING to cable.
- ④ Strip cable per dimension given and loosen braid.
- ⑤ Secure PLUG BODY to jig for soldering.
- ⑥ Solder stripped cable to pin.
- ⑦ Fasten CRIMP using hand crimp tool (SA-HCT^①).
- ⑧ Lock PLUG HOUSING and PLUG BODY using tightening force displayed on Table 1.
- ⑨ Tighten WRENCH BOLT using 0.3N force onto one of two embossed parts of crimp.
- ⑩ Cover RUBBER BUSHING onto PLUG HOUSING.

^① See below for information on SA-HCT.

Diagram 1

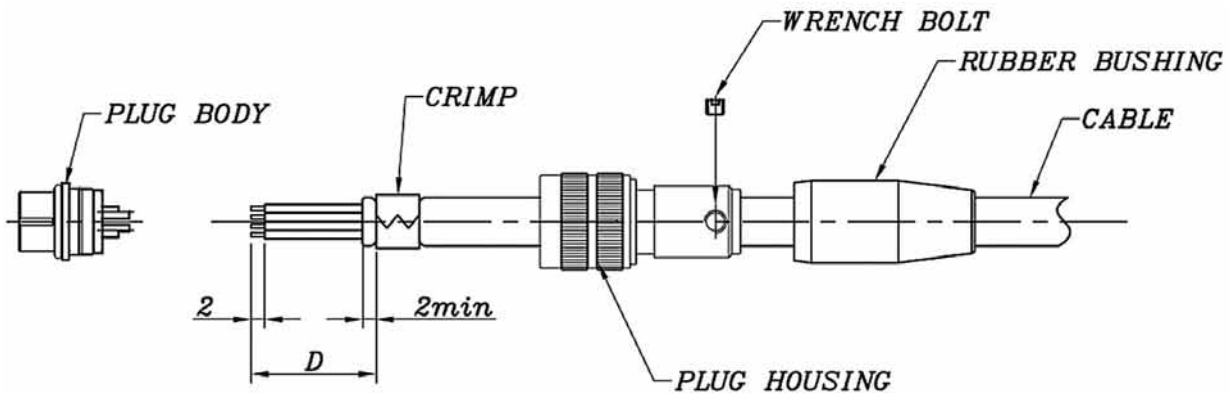

Table 1

unit : mm

Size	Spanner Jaw	D (Dimension)	Tightening Force	Notes
SW - 8	8	10	1.5N · m (15kg · cm)	SA-HCT size $\varnothing 5.5$
SW - 10	10	16	2.0N · m (20kg · cm)	SA-HCT size $\varnothing 7.0$

SA-HCT (Hand Crimp Tool)



Specially designed for Sam Woo's connector, the low-cost and efficient SA-HCT provides the best crimping results.

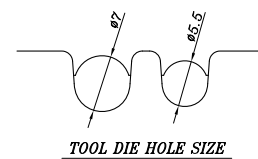

Specifications subject to change without notice. Consult Sam Woo Electronics for the latest specifications.

SW Receptacle PCB Hole Layout

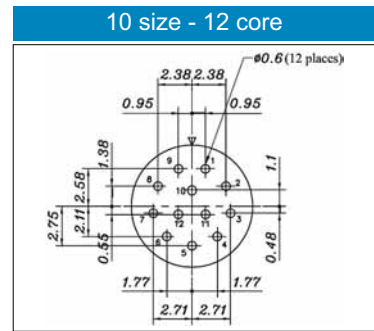
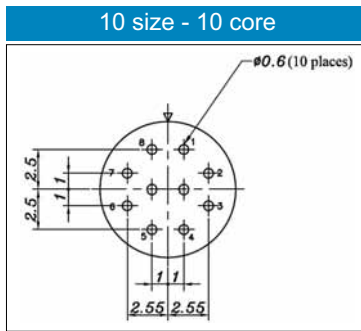
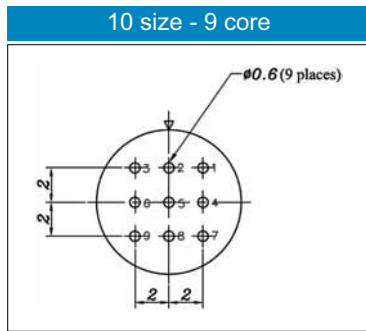
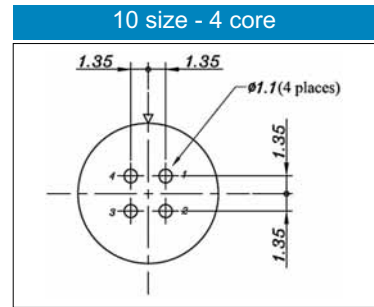
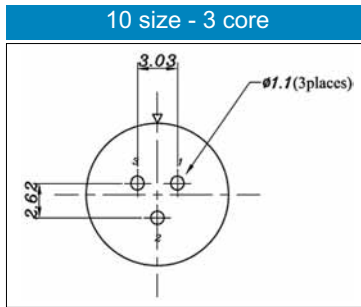
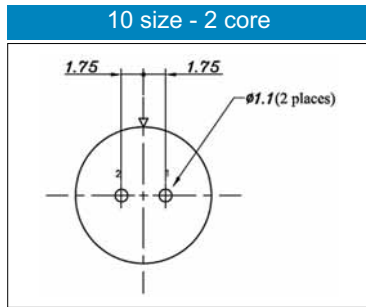
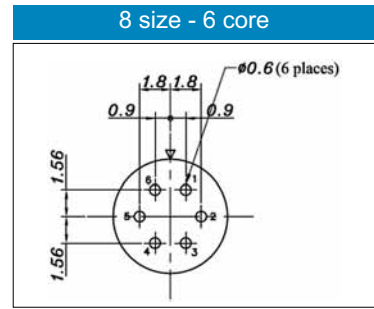
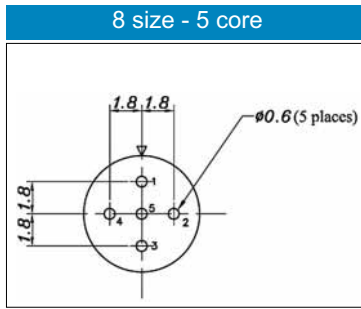
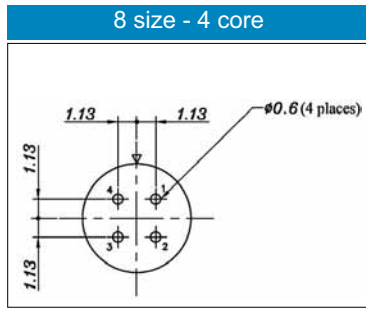

SW Receptacle Panel Layout

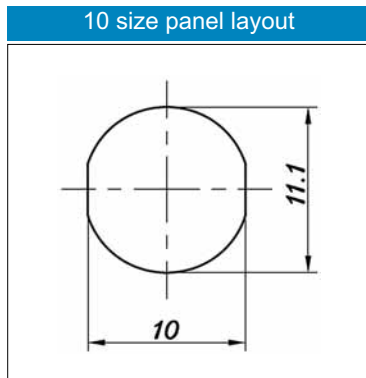
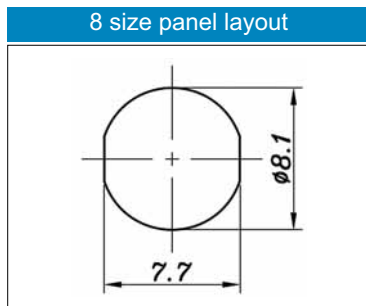

Specifications subject to change without notice. Consult Sam Woo Electronics for the latest specifications.